

Specifications

AUTOgel[®] 80

- 25-gallon, High Density, Polyethylene, Gel Spray Tank with Lid
- Heavy-duty, Lightning Mixer
- Heavy-duty, 11-gauge, Stainless Steel Base
- 1.5 x 1.5 Stainless Steel Square Tubing Frame and Handle
- Two Fixed and Two Swivel, Heavy-duty, Casters
- Pressure Regulator and Gauge
- Air-driven Dispensing Pump
- Heavy-duty, 1/2" x 50' Hose Assembly
- Heavy-duty, Stainless Steel Ball Valve, Wand and Nozzle
- Maximum Operating Pressure: 100 psig
- Maximum Temperature: 120°F

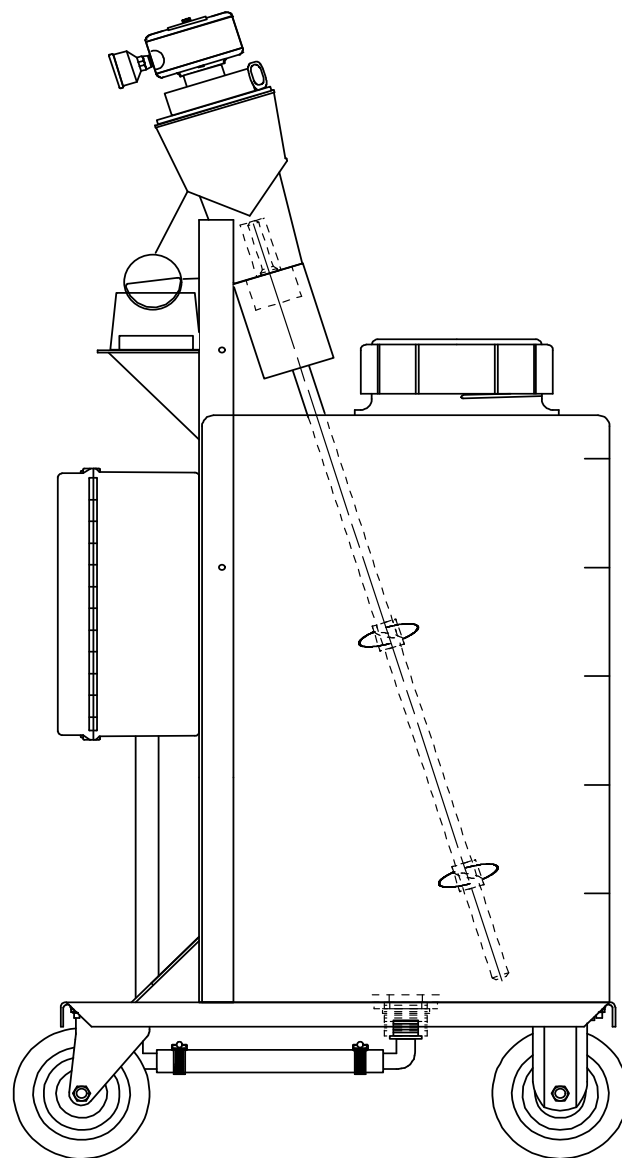

Version: 20272B