

Specifications

AUTOrinse® 2530

- Mobile Washer
- Heavy-duty, Stainless Steel, 1 1/2" x 1 1/2" Tubing Frame
- 300 psig System
- Two, 1/2" x 50' Heavy-duty, Hose & Nozzle Assemblies (at 12.5 gpm)
- Two, AUTOfoam®50/AUTOfood®50 (combination customer choice) with 1/2", Heavy-duty, Foam Hose and Nozzle Assemblies
- Multi-stage Pump
- Two Fixed and Two Swivel, Heavy-duty, Casters
- Two, 2.5-gallon Jerrican Holders
- Stainless Steel Piping
- 1 1/4 Inch Inlet Piping
- NEMA 4X Motor Starter and Enclosure
- Heavy-duty, Flow Switch
- 50-gauge, 12/4, Heavy-duty, Power Cord
- Start/Stop Buttons, Low Voltage
- Heavy-duty, Pressure Gauge
- Electrical: 3 Phase

Volts: 280 - 230/460

Amps: 13.2 - 12 / 6

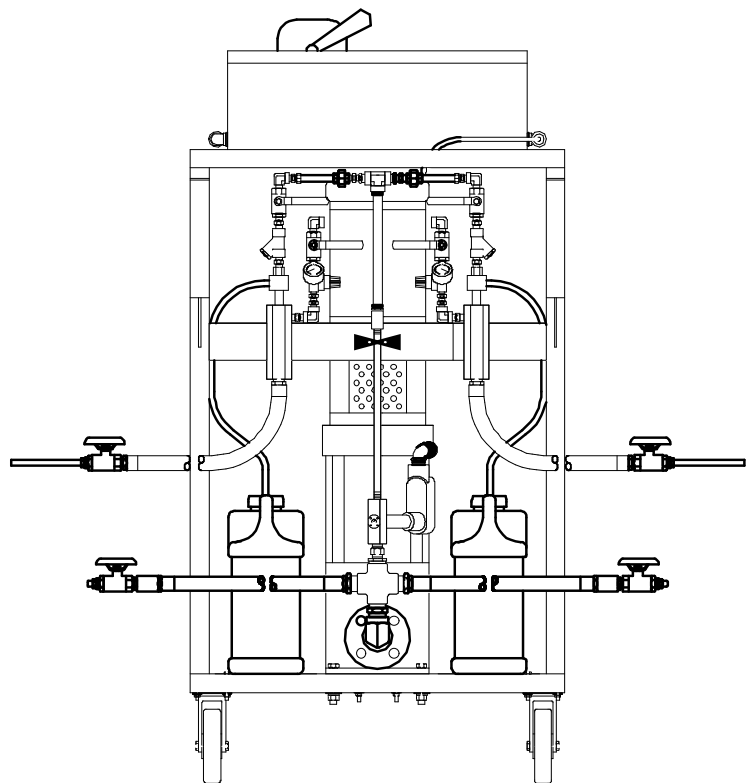

Version: 20450M