

Specifications

AUTOtransfer[®]W2

- Wall-mounted, Air-driven, Chemical Pump
- Heavy-duty, 10-gauge Stainless Steel, Wall-mounted Base
- 0 to 30 gpm Diaphragm Pump
- Heavy-duty Suction Assembly
- Solenoid Actuated Air Supply

Utilities

- Air Flow: 54 scfm Maximum
- Air Supply: 100 psig Maximum

Electrical

- 0.05 AMP at 120 VAC

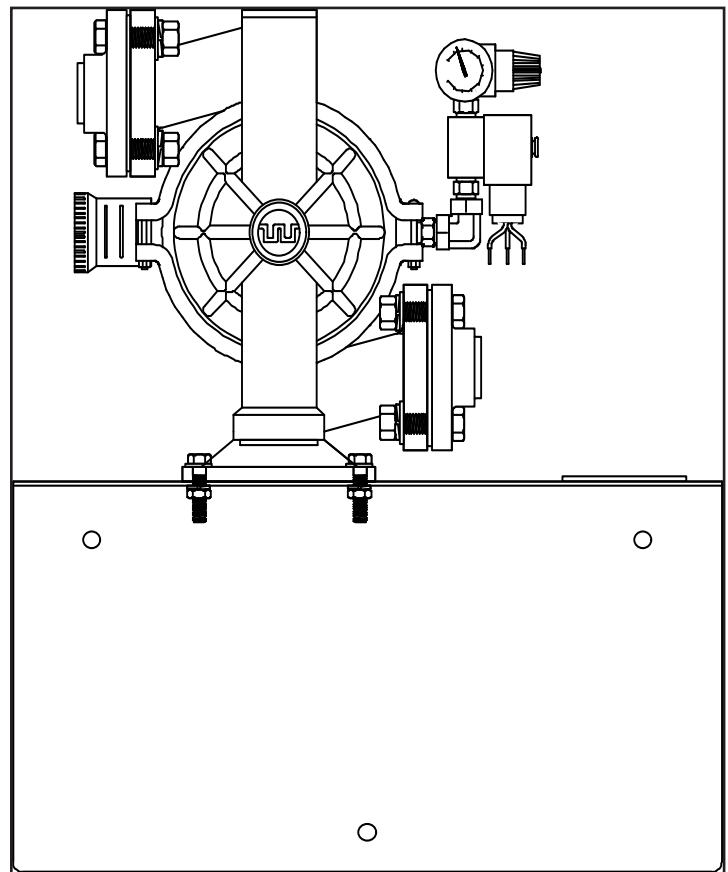

Version: 20503E